

Incremental encoders

Miniature magnetic	2430 / 2440 (shaft / hollow shaft)	RS422
---------------------------	---	--------------



Thanks to their non-contact magnetic scanning technology the miniature-format encoders 2430 and 2440 guarantee exceptional ruggedness – and this with a resolution of up to 256 pulses per revolution.

As a result of their compact outer diameter of only 24 mm, they are ideal for use where installation space is restricted.

High rotational speed	Temperature range	Shock / vibration resistant	Short-circuit proof	Reverse polarity protection	Magnetic sensor technology

Magnetically robust

- The non-contact magnetic technology prevents wear and guarantees a long service life.
- Multiple clamping affords high strain relief to the cable outlet, ensuring longer life.
- Wide temperature range from -20°C up to +85°C.
- Flexible connection possibilities: can be supplied with radial or axial cable outlet.

Compact power

- Resolution up to 256 pulses per revolution.
- Shaft and hollow shaft version.

Order code	8.2430	. X X 6 X . XXXX
Shaft version	Type	a b c d e
a Flange	1 = \varnothing 24 mm [0.94"] 3 = \varnothing 28 mm [1.10"] 2 = \varnothing 30 mm [1.18"]	d Type of connection 1 = axial cable, 2 m [5.56'] PVC A = axial cable, special length PVC *) 2 = radial cable, 2 m [5.56'] PVC B = radial cable, special length PVC *) *) Available special lengths (connection types A, B): 3, 5, 8, 10, 15 m [9.84, 16.40, 26.25, 32.80, 49.21'] order code expansion .XXXX = length in dm ex.: 8.2430.126A.0256.0030 (for cable length 3 m)
b Shaft ($\varnothing \times L$)	1 = \varnothing 4 x 10 mm [0.16 x 0.39"] 3 = \varnothing 5 x 10 mm [0.20 x 0.39"], with flat 2 = \varnothing 6 x 10 mm [0.24 x 0.39"]	e Pulse rate 1 ... 128 (factory programmable) 256 (e.g. 128 pulses => 0128) <i>Optional on request</i> - other pulse rates
c Output circuit / power supply	6 = RS422 (with inverted signal) / 5 V DC	

Order code	8.2440	. 1 X 6 X . XXXX
Hollow shaft	Type	a b c d e
a Flange	1 = \varnothing 24 mm [0.94"]	d Type of connection 1 = axial cable, 2 m [5.56'] PVC A = axial cable, special length PVC *) 2 = radial cable, 2 m [5.56'] PVC B = radial cable, special length PVC *) *) Available special lengths (connection types A, B): 3, 5, 8, 10, 15 m [9.84, 16.40, 26.25, 32.80, 49.21'] order code expansion .XXXX = length in dm ex.: 8.2440.126A.0256.0030 (for cable length 3 m)
b Blind hollow shaft (insertion depth max. 14 mm [0.55"])	1 = \varnothing 4 mm [0.16"] 2 = \varnothing 6 mm [0.24"]	e Pulse rate 1 ... 128 (factory programmable) 256 (e.g. 128 pulses => 0128) <i>Optional on request</i> - other pulse rates
c Output circuit / power supply	6 = RS422 (with inverted signal) / 5 V DC	

Incremental encoders

Miniature magnetic	2430 / 2440 (shaft / hollow shaft)	RS422
---------------------------	---	--------------

Mounting accessory for shaft encoders		Order no.
Coupling	bellows coupling ø 15 mm [0.59"] for shaft 4 mm [0.16"]	8.0000.1202.0404

Further accessories can be found in the accessories section or in the accessories area of our website at: www.kuebler.com/accessories.
 Additional connectors can be found in the connection technology section or in the connection technology area of our website at: www.kuebler.com/connection_technology.

Technical data

Mechanical characteristics		Electrical characteristics	
Maximum speed	12000 min ⁻¹	Output circuit	RS422 (TTL compatible)
Mass moment of inertia	approx. 0.1 x 10 ⁻⁶ kgm ²	Power supply	5 V DC (±5 %)
Starting torque - at 20°C [68°F]	< 0.01 Nm	Power consumption with inverted signal (no load)	typ. 40 mA max. 90 mA
Shaft load capacity	radial 10 N axial 20 N	Permissible load / channel	max. +/- 20 mA
Weight	approx. 0.06 kg [2.11 oz]	Pulse frequency	max. 300 kHz
Protection acc. to EN 60529	housing side IP65 (IP67 on request) flange side IP50 (IP67 on request)	Signal level	HIGH min. 2.5 V LOW max. 0.5 V
Working temperature range	-20°C ... +85°C [-4°F ... +185°F]	Rising edge time t_r	max. 200 ns
Materials	shaft / hollow shaft stainless steel clamping flange MS58	Falling edge time t_f	max. 200 ns
Shock resistance acc. to EN 60068-2-27	1000 m/s ² , 6 ms	Min. pulse edge interval	0.5 µs ¹⁾
Vibration resistance acc. to EN 60068-2-6	100 m/s ² , 55 ... 2000 Hz	Short circuit proof outputs²⁾	yes ³⁾
		Reverse polarity protection of the power supply	no
		CE compliant acc. to	EMC guideline 2014/30/EU RoHS guideline 2011/65/EU

Terminal assignment

Output circuit	Type of connection	Cable (isolate unused cores individually before initial start-up)								
6 with inv. signal	1, 2, A, B	Signal:	0 V	+V	A	\bar{A}	B	\bar{B}	0	$\bar{0}$
		Core color:	WH	BN	GN	YE	GY	PK	BU	RD

- +V: Encoder power supply +V DC
- 0 V: Encoder power supply ground GND (0 V)
- A, \bar{A} : Incremental output channel A
- B, \bar{B} : Incremental output channel B
- 0, $\bar{0}$: Reference signal

1) For max. speed use a counter with input frequency of min. 500 kHz.
 2) If power supply correctly applied.
 3) Only one channel allowed to be shorted-out:
 If +V = 5 V DC short circuit to channel, 0 V, or +V is permitted.

Incremental encoders

Miniature magnetic	2430 / 2440 (shaft / hollow shaft)	RS422
---------------------------	---	--------------

Dimensions shaft version

Dimensions in mm [inch]

Flange type 1, \varnothing 24 [0.94]

- 1 min R50 [1.97]
- 2 3 x M3, 4 [0.16] deep

D	Fit	L
4 [0.16]	f7	10 [0.39]
5 [0.20]	f7	10 [0.39]
6 [0.24]	f7	10 [0.39]

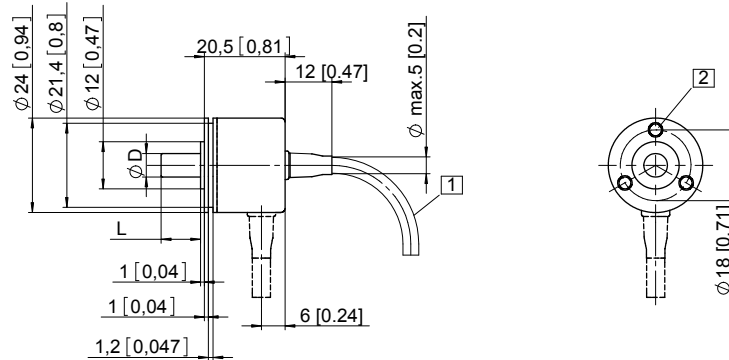

Flange type 2, \varnothing 30 [1.18]

Flange type 3, \varnothing 28 [1.10]

- 1 min R50 [1.97]
- 2 2 x M3, 4 [0.16] deep

D	Fit	L
4 [0.16]	f7	10 [0.39]
5 [0.20]	f7	10 [0.39]
6 [0.24]	f7	10 [0.39]

Flange type	A	B
2	\varnothing 30 [1.18]	3 [0.12]
3	\varnothing 28 [1.10]	2 [0.08]

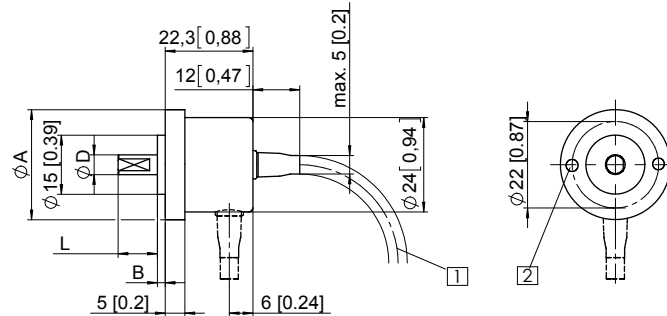

Dimensions hollow shaft version

Dimensions in mm [inch]

Flange type 1, \varnothing 24 [0.94]

- 1 4 x M3 DIN 915 - SW1.5

D	Fit	L
4 [0.16]	H7	14 [0.55]
6 [0.24]	H7	14 [0.55]
1/4"	H7	14 [0.55]

L = insertion depth max. blind hollow shaft

