

Linear measuring technology

Draw-wire mechanics with encoder or analog sensor	Draw-wire encoder D135	Measuring length max. 42.5 m Traverse speed max. 5 m/s
--	-------------------------------	---



These draw-wire mechanics D135 can be used up to a measuring length of 42.5 meters. This draw-wire mechanics may be combined with the proven Kübler Sendix encoders with incremental or absolute interface, as well as with analog sensors.

With its compact construction, the D135 suits perfectly all measuring tasks from 8 up to 42.5 meters.



Max. acceleration 140 m/s ²	Long service life	Temperature -20°C...+90°C	High protection level IP	Reverse polarity protection

Robust

- The titanium-anodized aluminum housing and the stainless steel wires allow for using the mechanics even in harsh conditions.
- Wear-free wire exit thanks to special plain bearing guide.
- Various wire types and wire fastenings.

Versatile

- High traverse speed and high acceleration.
- Flexible mounting thanks to fastening tabs or fastening grooves.
- Various connection possibilities available.
- Interchangeable encoders (interchangeable installation).

Order code with encoder (incremental, absolute)

D8.4D1 . XXXX . XXXX . XXXX
Type a b c d e

- a** *Measuring range*
- 0800 = 8 000 mm
 - 1000 = 10 000 mm
 - 1200 = 12 000 mm
 - 1500 = 15 000 mm
 - 2000 = 20 000 mm
 - 2500 = 25 000 mm
 - 3000 = 30 000 mm
 - 3500 = 35 000 mm
 - 4000 = 40 000 mm
 - 4250 = 42 500 mm

- b** *Encoder used*
- 00 = Sendix 5000, incremental
 - M3 = Sendix M5863, absolute
 - F3 = Sendix F5863, absolute
 - 63 = Sendix 5863, absolute
 - M8 = Sendix M5868, absolute
 - F8 = Sendix F5868 absolute
 - 68 = Sendix 5868, absolute

- c** *Output circuit*
depends on the encoder used
- d** *Type of connection*
depends on the encoder used
- e** *Resolution / Protocol / Options*
depends on the encoder used

Optional on request

- Other measuring ranges
- Cable diameter 1 mm
- Eyelet or M4 wire fastening instead of wire clip
- Modified cable and/or connector orientation
- Modified cable outlet direction
- Sensor protection level IP67
- Improved linearity (0.02 %)

Standard resolutions for draw-wire with incremental encoder Sendix 5000

Drum circumference [mm]	333.33	333.33	333.33
Pulses / revolution [ppr]	1000	2000	4000
Pulses / mm	3	6	12
Resolution [mm]	0.33	0.17	0.08

Standard resolutions for draw-wire with absolute encoder Sendix M5863 (12 bit ST) or M5868 (12 bit ST, programmable via bus)

Drum circumference [mm]	333.33
Pulses / revolution [ppr]	4096
Pulses / mm	12.3
Resolution [mm]	0.08

Draw-wire mechanics with encoder or analog sensor

Draw-wire encoder D135

Measuring length max. 42.5 m
 Traverse speed max. 5 m/s

Recommended standard variants (with incremental, absolute encoder)

Order no. draw-wire encoder	Mounted encoder	Interface	Power supply	Type of connection	Resolution / Protocol	Option
D8.xD1.xxxx.0054.2000	Sendix 5000 (8.5000.8354.2000)	Push-pull with inverted signal	10 ... 30 V DC	1 x radial M12 connector	2000 ppr	-
D8.xD1.xxxx.M324.G222	Sendix M5863 (8.M5863.3524.G222)	SSI	10 ... 30 V DC	radial M12 connector	4096 ppr / SSI-Gray-Code	-
D8.xD1.xxxx.M824.2122	Sendix M5868 (8.M5868.3524.2122)	CANopen	10 ... 30 V DC	radial M12 connector	CANopen encoder profil DS406 V4.0	-

Other variants (with absolute encoder)

Order no. draw-wire encoder	Mounted encoder	Interface	Power supply	Type of connection	Resolution / Protocol	Option
D8.xD1.xxxx.F326.G223	Sendix F5863 (8.F5863.1226.G223)	SSI	10 ... 30 V DC	1 x radial M12 connector	4096 ppr / SSI-Gray-Code	SET button + status LED
D8.xD1.xxxx.6326.G223	Sendix 5863 (8.5863.1226.G223)	SSI	10 ... 30 V DC	1 x radial M12 connector	4096 ppr / SSI-Gray-Code	SET button + status LED
D8.xD1.xxxx.F82E.2123	Sendix F5868 (8.F5868.122E.2123)	CANopen	10 ... 30 V DC	1 x radial M12 connector	CANopen encoder profile DS406 V3.2	SET button
D8.xD1.xxxx.6822.2123	Sendix 5868 (8.5868.1222.2123)	CANopen	10 ... 30 V DC	2 x radial M12 connector	CANopen encoder profile DS406 V3.2	SET button
D8.xD1.xxxx.M834.3222	Sendix M5868 (8.M5868.3534.3222)	SAE J1939	10 ... 30 V DC	1 x radial M12 connector	SAE J1939	-
D8.xD1.xxxx.6832.3113	Sendix 5868 (8.5868.1232.3113)	PROFIBUS	10 ... 30 V DC	3 x radial M12 connector	Profibus-DP V0 encoder profile Class 2	SET button
D8.xD1.xxxx.68B2.B212	Sendix 5868 (8.5868.12B2.B212)	EtherCAT	10 ... 30 V DC	3 x radial M12 connector	EtherCAT with CoE 3.2.10	-
D8.xD1.xxxx.68C2.C212	Sendix 5868 (8.5868.12C2.C212)	PROFINET IO	10 ... 30 V DC	3 x radial M12 connector	PROFINET encoder profile version 4.1	-
D8.xD1.xxxx.F8AN.A222	Sendix F5868 (8.F5868.12AN.A222)	EtherNet/IP	10 ... 30 V DC	3 x axial M12 connector	EtherNet/IP	-

Order code with encoder (analog, scalable with limit switch function)

D8.4D1 . XXXX . M1XX . XXXX

Type **a** **b** **c** **d** **e**

- a** *Measuring range*
 0800 = 8 000 mm
 1000 = 10 000 mm
 1200 = 12 000 mm
 1500 = 15 000 mm
 2000 = 20 000 mm
 2500 = 25 000 mm
 3000 = 30 000 mm
 3500 = 35 000 mm
 4000 = 40 000 mm
 4250 = 42 500 mm

- b** *Encoder used*
 M1 = Sendix M5861, absolute ¹⁾

- c** *Output circuit*
 depends on the encoder used

- d** *Type of connection*
 depends on the encoder used

- e** *Resolution / Protocol / Options*
 depends on the encoder used

- Optional on request*
 - Other measuring ranges
 - Cable diameter 1 mm
 - Eyelet or M4 wire fastening instead of wire clip
 - Modified cable and/or connector orientation
 - Modified cable outlet direction
 - Sensor protection level IP67

Recommended standard variants (with encoder analog, scalable with limit switch function)

Order no. draw-wire encoder	Mounted encoder	Interface	Power supply	Type of connection	Resolution / Protocol	Option
D8.xD1.xxxx.M134.3612	Sendix M5861 (8.M5861.3534.3612)	Analog, 4 ... 20 mA	10 ... 30 V DC	radial M12 connector	12 Bit / 4 ... 20 mA	scalable without limit switch function ²⁾
D8.xD1.xxxx.M144.4612	Sendix M5861 (8.M5861.3544.4612)	Analog, 0 ... 10 V	15 ... 30 V DC	radial M12 connector	12 Bit / 0 ... 10 V	scalable without limit switch function ²⁾
D8.xD1.xxxx.M134.3512	Sendix M5861 (8.M5861.3534.3512)	Analog, 4 ... 20 mA	10 ... 30 V DC	radial M12 connector	12 Bit / 4 ... 20 mA	scalable with limit switch function ³⁾
D8.xD1.xxxx.M144.4512	Sendix M5861 (8.M5861.3544.4512)	Analog, 0 ... 10 V	15 ... 30 V DC	radial M12 connector	12 Bit / 0 ... 10 V	scalable with limit switch function ³⁾

Order code with analog sensor (scaled to measuring range)

D8.3D1 . XXXX . XXX X . 0000

Type **a** **b** **c**

- a** *Measuring range*
 0800 = 8 000 mm
 1000 = 10 000 mm
 1500 = 15 000 mm
 2000 = 20 000 mm
 2500 = 25 000 mm
 3000 = 30 000 mm
 3500 = 35 000 mm
 4000 = 40 000 mm

- b** *Analog sensor output / power supply*
 A11 = 4 ... 20 mA / 12 ... 30 V DC
 A22 = 0 ... 10 V / 12 ... 30 V DC
 A33 = potentiometer 1 k Ω / max. 30 V DC

- c** *Type of connection*
 1 = axial cable, 2 m [6.56'] PVC
 3 = axial M12 connector, 4-pin

- Optional on request*
 - Other measuring ranges
 - Cable diameter 1 mm
 - Eyelet or M4 wire fastening instead of wire clip
 - Modified cable and/or connector orientation
 - Modified cable outlet direction
 - Sensor protection level IP67
 - Increased temperature range -40°C ... +85°C and -20°C ... +120°C

1) With ccw option.

2) Delivery condition: scaled to measuring range.
 Description for scaling and limit switch function see data sheet M5861.

3) Delivery condition: unscaled.

Description for scaling and limit switch function see data sheet M3661.

Linear measuring technology

Draw-wire mechanics with encoder or analog sensor	Draw-wire encoder D135	Measuring length max. 42.5 m Traverse speed max. 5 m/s
--	-------------------------------	---

Accessories for draw-wire encoder	Dimensions in mm [inch]	Order no.
--	-------------------------	-----------

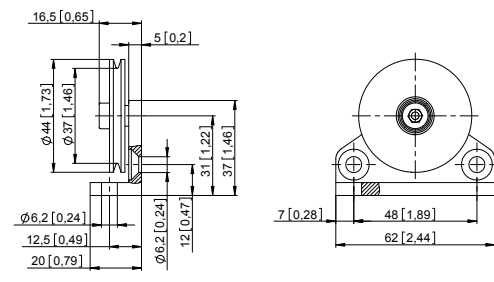
Guide pulley 		Technical data: - mounting bracket (anodized alum.) - guide pulley (plastic POM) - ball bearing (type 696-2R5) Scope of delivery: - 2 x countersunk screws for lateral fixing - 2 x hexagonal screws for fixing on a flat surface	8.0000.7000.0045
--	---	---	-------------------------

Connection technology for analog sensor	Order no.
--	-----------

Cordset, pre-assembled	M12 female connector with coupling nut, 5-pin 2 m [6.56'] PVC cable	05.00.6081.2211.002M
	M12 male connector with external thread, 4-pin 2 m PVC-Kabel	05.00.6031.4411.002M
Connector, self-assembly (straight)	M12 female connector with coupling nut, housing metal, 5-pin M12 female connector with coupling nut, housing metal/plastic, 5-pin	8.0000.5116.0000 05.B-8151-0/9
Connector, self-assembly (right-angle)	M12 female connector with coupling nut, housing plastic, 5-pin	05.B-8251-0/9

Additional connectors can be found in the connection technology section or in the connection technology area of our website at: www.kuebler.com/connection_technology.

Technical data

Mechanical characteristics (draw-wire mechanics)						
Measuring range		8000 mm	10000 mm 12000 mm 15000 mm	20000 mm	25000 mm 30000 mm	35000 mm 40000 mm 42500 mm
Extension force	F_{min}	7.2 N	8.7 N	7.0 N	7.3 N	7.0 N
	F_{max}	16.0 N	16.9 N	12.4 N	15.7 N	14.1 N
Max. speed		10 m/s	6 m/s	5 m/s	5 m/s	5 m/s
Max. acceleration		140 m/s ²	80 m/s ²	60 m/s ²	60 m/s ²	60 m/s ²
Linearity	with analog output	±0.1 % (of the measuring range)				
	with encoder	±0.05 % (of the measuring range) ±0.02 % (of the measuring range) ¹⁾				
Weight		depending on the measuring and the sensor/encoder used				
Material	housing	titanium-anodized aluminum				
	wire	stainless steel ø 0.5 mm (ø 1 mm can be supplied as a special up to measuring range 20000 mm)				
Protection acc. to EN 60529		IP65 (sensor)				

Electrical characteristics (digital output)
--

The electrical characteristics of the draw-wire mechanics with digital output can be found in the data sheets of the encoders.

Operating principle

Construction
The core of a draw-wire device is a drum mounted on bearings, onto which a wire is wound. Winding takes place via a spring-loaded device.

Note
Exceeding the maximum extension length of the draw-wire will lead to damage to the wire and the mechanics.

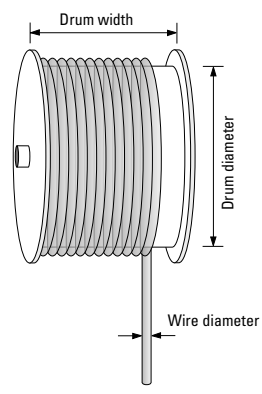

1) On request for encoder version: **00, F3, 63, F8, 68** (see order code **b**).

Linear measuring technology

**Draw-wire mechanics
with encoder or analog sensor**

Draw-wire encoder D135

**Measuring length max. 42.5 m
Traverse speed max. 5 m/s**

Electrical characteristics (analog sensor, scaled to measuring range)

Version	A22	A11	A33
Analog output	0 ... 10 V	4 ... 20 mA	potentiometer
Output	0 ... 10 V / galv. isolated, 4 conductors	4 ... 20 mA / 2 conductors	1 kΩ
Power supply	12 ... 30 V DC	12 ... 30 V DC	max. 30 V DC
Recommended slider current	–	–	< 1 μA
Max. current consumption	22.5 mA (no load)	50 mA	–
Reverse polarity protection	yes	yes	–
Working temperature	-20°C ... +85°C [-4°F ... +185°F] -40°C ... +85°C [-40°F ... +185°F] ¹⁾	-20°C ... +85°C [-4°F ... +185°F] -40°C ... +85°C [-40°F ... +185°F] ¹⁾	-20°C ... +85°C [-4°F ... +185°F] -40°C ... +85°C [-40°F ... +185°F] ¹⁾ -20°C ... +120°C [-4°F ... +248°F] ¹⁾

Connection diagrams

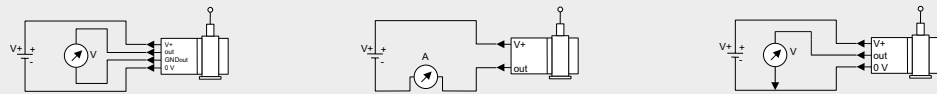

CE compliant acc. to

EMC guideline 2014/30/EU
RoHS guideline 2011/65/EU

Technology in detail

Various wire types and wire fastenings

- Wire types:
- 0.5 mm (V2A) ²⁾
 - 0.51 mm (V4A)
 - 1.0 mm (V4A)
 - 1.0 mm plastic-coated (V4A = 0.81 mm, plastic 0.19 mm)
 - 0.6 mm (Coramid)

Wire fastenings:

- Clip ²⁾ M4 thread Eyelet



Individual wire outlet and cable / connector orientation

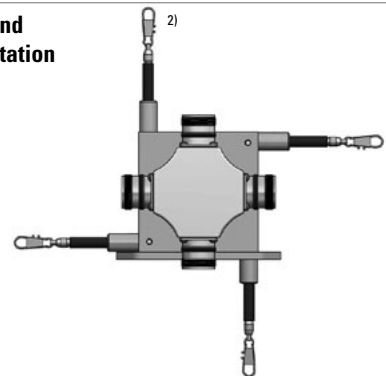

Extension wire



Application-specific installation possibilities

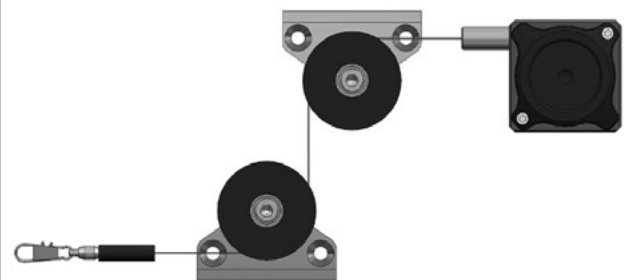

Terminal assignment (analog sensor A11, A22, A33)

Pin	1	2	3	4
Core color	BN	WH	BU	BK
0 ... 10 V	+V	Signal	0 V	0 V Sig.
4 ... 20 mA	+V	n. c.	Signal	n. c.
1 kΩ	+V	Slider	0 V	n. c.

Top view of mating side, male contact base

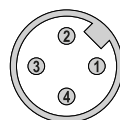

M12 connector, 4-pin

1) Optional on request.
2) Standard.

Draw-wire mechanics with encoder or analog sensor **Draw-wire encoder D135** **Measuring length max. 42.5 m**
Traverse speed max. 5 m/s

Dimensions

Dimensions in mm [inch]

Draw-wire mechanics, measuring range 8000 mm with encoder

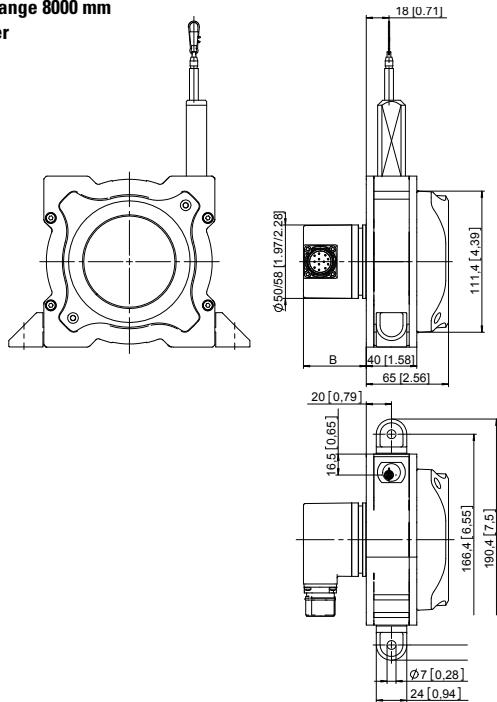

with analog output

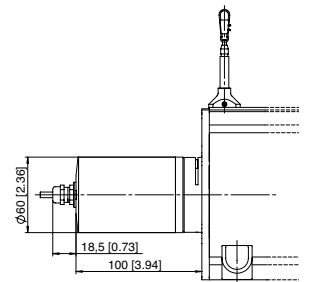

Dimension B depends on the encoder used

Encoder		B
Sendix incremental (5000)	D8.4D1.xxxx.00xx.xxxx	37.0 [1.46]
Sendix absolute (F5863)	D8.4D1.xxxx.F3xx.xxxx	49.5 [1.95]
Sendix absolute (5863)	D8.4D1.xxxx.63xx.xxxx	49.5 [1.95]
Sendix absolute (F5868, CANopen)	D8.4D1.xxxx.F8xx.21xx	70.0 [2.76]
Sendix absolute (F5868, EtherNet/IP)	D8.4D1.xxxx.F8xx.A2xx	59.5 [2.34]
Sendix absolute (5868)	D8.4D1.xxxx.68xx.xxxx	77.2 [3.04]
Sendix absolute (M586x)	D8.4D1.xxxx.Mxxx.xxxx	49.8 [1.96]

Linear measuring technology

Draw-wire mechanics with encoder or analog sensor

Draw-wire encoder D135

**Measuring length max. 42.5 m
Traverse speed max. 5 m/s**

Dimensions

Dimensions in mm [inch]

Draw-wire mechanics, measuring range 10000 - 12000 mm with encoder

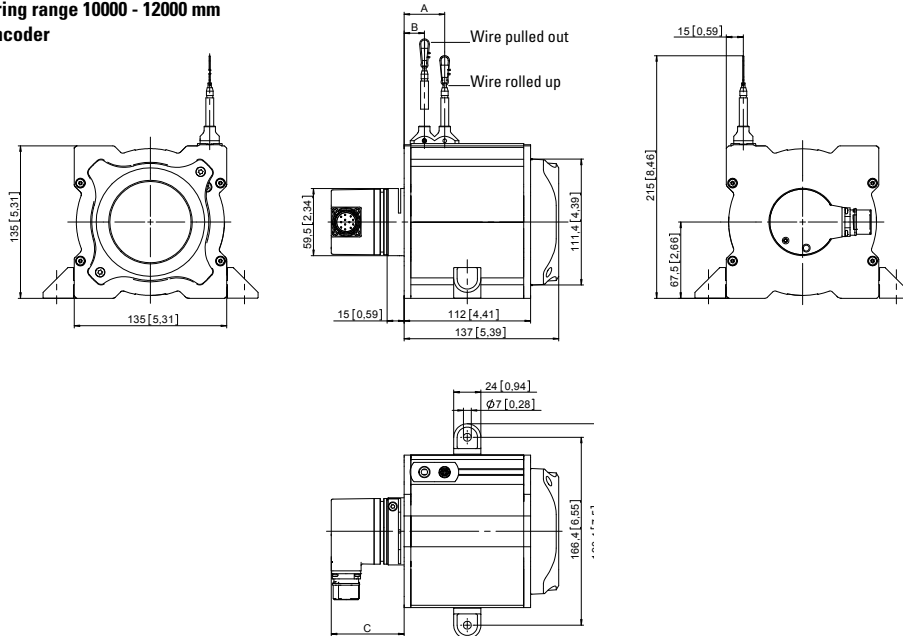

with analog output

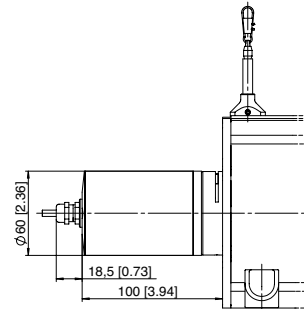

Draw-wire mechanics, measuring range 15000 - 20000 mm with encoder

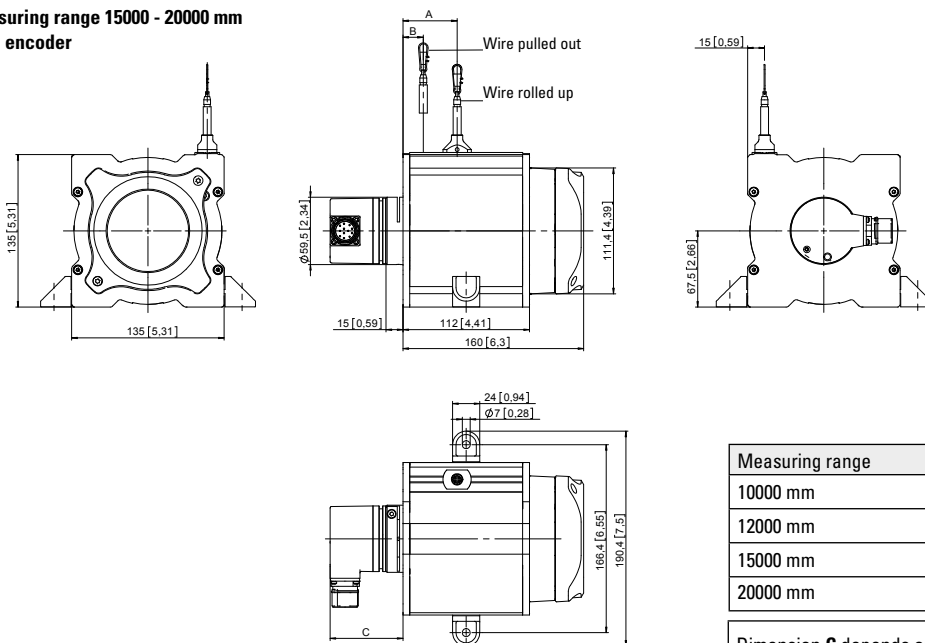

with analog output

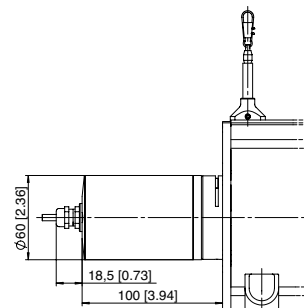

Measuring range	A - Wire rolled up	B - Wire pulled out
10000 mm	33 [1.30]	18 [0.71]
12000 mm	36 [1.42]	18 [0.71]
15000 mm	41 [1.61]	18 [0.71]
20000 mm	48 [1.89]	18 [0.71]

Dimension C depends on the encoder used		
Encoder		C
Sendix incremental (5000)	D8.4D1.xxxx.00xx.xxxx	60.0 [2.36]
Sendix absolute (F5863)	D8.4D1.xxxx.F3xx.xxxx	72.5 [2.85]
Sendix absolute (5863)	D8.4D1.xxxx.63xx.xxxx	72.5 [2.85]
Sendix absolute (F5868, CANopen)	D8.4D1.xxxx.F8xx.21xx	93.0 [3.66]
Sendix absolute (F5868, EtherNet/IP)	D8.4D1.xxxx.F8xx.A2xx	82.5 [3.25]
Sendix absolute (5868)	D8.4D1.xxxx.68xx.xxxx	100.2 [3.94]
Sendix absolute (M586x)	D8.4D1.xxxx.Mxxx.xxxx	72.8 [2.87]

Linear measuring technology

Draw-wire mechanics with encoder or analog sensor	Draw-wire encoder D135	Measuring length max. 42.5 m Traverse speed max. 5 m/s
--	-------------------------------	---

Dimensions

Dimensions in mm [inch]

Draw-wire mechanics, measuring range 25000 - 30000 mm with encoder

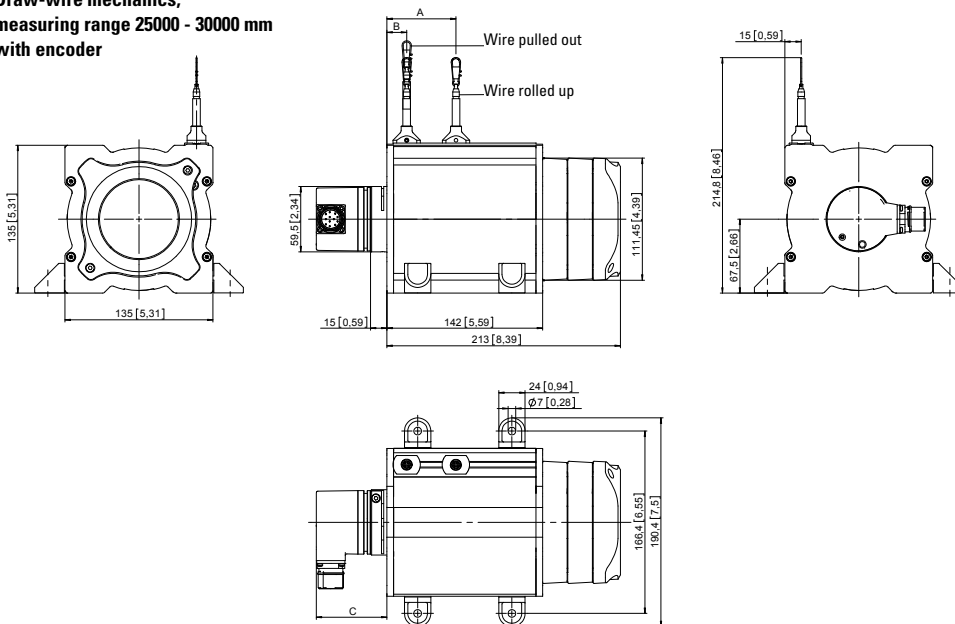

with analog output

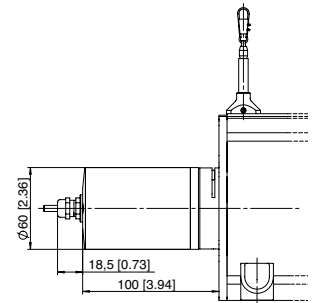

Draw-wire mechanics measuring range 35000 - 42500 mm with encoder

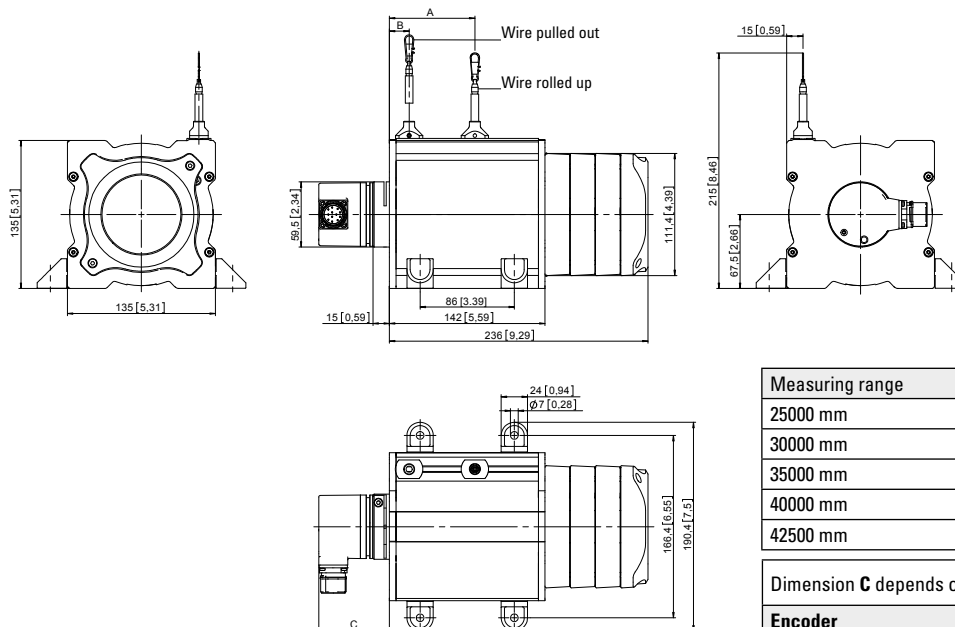

with analog output

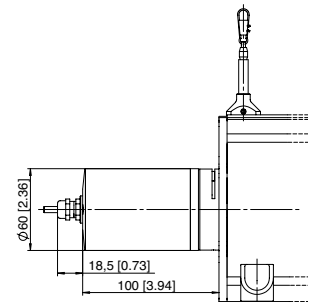

Measuring range	A - Wire rolled up	B - Wire pulled out
25000 mm	56 [2.02]	18 [0.71]
30000 mm	63 [2.48]	18 [0.71]
35000 mm	71 [2.80]	18 [0.71]
40000 mm	78 [3.07]	18 [0.71]
42500 mm	82 [3.23]	18 [0.71]

Dimension C depends on the encoder used		
Encoder		C
Sendix incremental (5000)	D8.4D1.xxxx.00xx.xxxx	60.0 [2.36]
Sendix absolute (F5863)	D8.4D1.xxxx.F3xx.xxxx	72.5 [2.85]
Sendix absolute (5863)	D8.4D1.xxxx.63xx.xxxx	72.5 [2.85]
Sendix absolute (F5868, CANopen)	D8.4D1.xxxx.F8xx.21xx	93.0 [3.66]
Sendix absolute (F5868, EtherNet/IP)	D8.4D1.xxxx.F8xx.A2xx	82.5 [3.25]
Sendix absolute (5868)	D8.4D1.xxxx.68xx.xxxx	100.2 [3.94]
Sendix absolute (M586x)	D8.4D1.xxxx.Mxxx.xxxx	72.8 [2.87]