

BKL/003

ECOFLEX® WITH CLAMPING HUB 3 Nm



PROPERTIES

FEATURES

- ▶ economically priced
- ▶ backlash free and torsionally stiff
- ▶ wear free and robust

DESIGN

Two clamping hubs, each with a clamping screw.
Operational from -40 to +200° C

MATERIAL

- ▶ **Bellows:** high grade stainless steel
- ▶ **Hubs:** aluminium

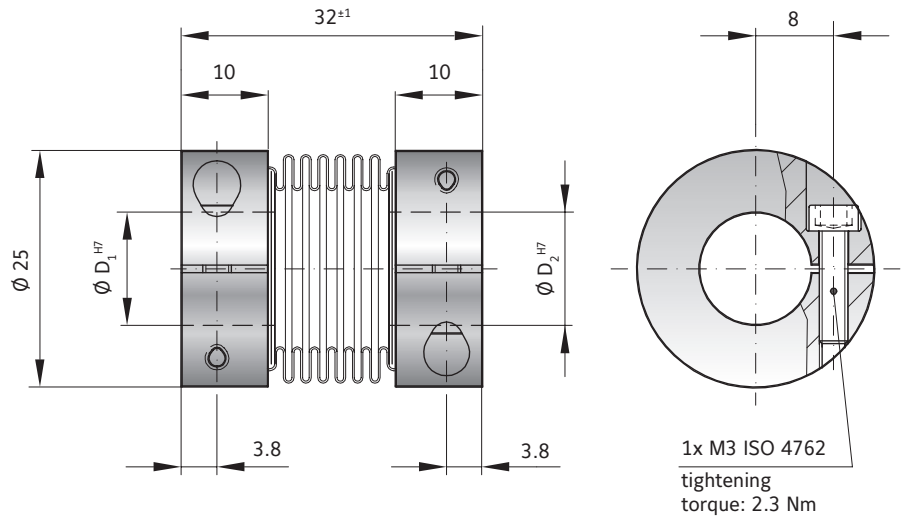

MODEL BKL/003

SIZE			3
Rated torque	(Nm)	T_{KN}	3
Standard bore diameters H7	(mm)	D_1, D_2	3 to 12.7
Moment of inertia	(gcm ²)	$J_{ges.}$	20
Approximate weight	(g)		23
Tightening torque of the fastening screws	(Nm)		2.3
Torsional stiffness	(Nm/rad)	C_T	994
Axial	(mm)	Max. values	1
Lateral	(mm)		0.2
Angular	(degree)		2

ECOFLEX®:

The low cost alternative for encoders, potentiometers, stepper motors, and small servo drives.

ORDERING EXAMPLE	BKL	003	3	6.35	XX
Model	●				
Size		●			
Bore D1 H7			●		
Bore D2 H7				●	
For custom features place an XX at the end of the part number and describe the special requirements (e.g. BKL / 003 / 3 / 6.35 / XX; XX=stainless steel hubs)					