

Safety Coupling
with two outer cones

optional
nickel-plated version
optional full stainless
steel version

optional
laserwelded

KBK/BAA

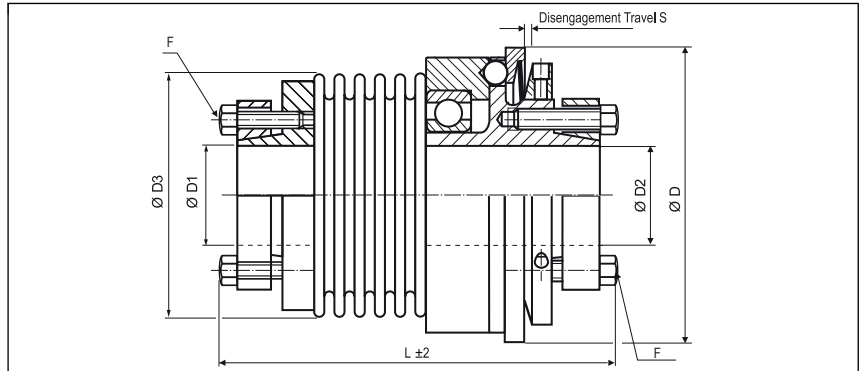

Order Code

KBK/BAA - 60 - 108 - 15H7 - 18H7 - 20Nm - C or D - 2

Type Size Length ØD1 (H7) ØD2 (H7) Disengagement Torque Torque Range
C = Single Position D = Multi Position Engagement

Size	Dimensions (mm)							Technical Data										
	Ø D	L	Ø D1	Ø D2	Ø D3	F	S	max. speed (1/min)	Mass (kg)	Moment of Inertia J (kg cm²)	Torque Range		Spring Stiffness			Misalignment		
	Outer Ø	Length	Bore Size (H7) min-max	Bore Size (H7) min-max		Screw ISO4017 TA (Nm)	1 TKN (Nm)				2 TKN (Nm)	torsional x10³ CT (Nm/rad)	radial CR (N/mm)	axial CA (N/mm)	radial Δ Kr (mm)	axial Δ Ka (mm)	angular Δ Kw (°)	
-10	49	66	5-14	5-14	40.5	M3	0.7	11650	0.27	0.6	3-7	5-10	8.1	120	27	0.15	0.4	1.5
		75	10#	10#		2.1							6.8	29	17	0.3	0.6	2
-30	64	78	12-20	12-20	56	M5	1.2	9540	0.74	3.0	5-15	10-30	38	720	50	0.15	0.6	1.5
		87	14#	14#		5.9							28	225	28	0.25	1	2
-60	79	97	15-32	15-25	66	M5	1.2	8180	1.41	8.6	12-35	20-60	75	1150	90	0.15	0.6	1.5
		108	24#	18#		8.7							50	340	50	0.25	1	2
-80	94	116	20-35	20-35	82	M6	2	6220	2.6	23	15-40	30-80	128	1200	80	0.2	0.5	1.5
		129	27#	27#		15							75	400	50	0.25	0.8	2
-150	94	116	20-35	20-35	82	M6	2	6220	2.6	23	50-130	65-150	155	2020	145	0.2	0.5	1.5
		129	27#	27#		15							105	595	85	0.25	0.8	2
-200	109	118	20-42	20-42	90	M6	2	5720	2.9	35	30-90	80-200	175	2500	147	0.2	0.5	1.5
		132	34#	34#		15							116	460	82	0.25	0.8	2
-300	119	141	25-50	25-50	110	M8	2	5200	4.6	70	60-200	150-300	502	6300	280	0.2	0.5	1.5
		152	41#	41#		25							285	1400	145	0.25	0.8	2
-500	129	159	35-55	35-55	122	M8	2	4470	6.8	121	80-250	200-500	690	7790	100	0.2	0.5	1.5
		171	45#	45#		36							320	970	85	0.25	1	2
-800	169	250	50-70	50-70	157	M12	2	3350	17.7	514	240-600	500-800	700	500	185	0.2	0.8	1.8
			58#	58#		85												
-1400	169	250	50-70	50-70	157	M12	2	3350	17.8	516	360-1000	900-1400	1270	700	275	0.2	0.8	1.8
			58#	58#		115												

Material	outer cone - steel bellows - stainless steel
Keyway	optional acc. DIN 6885 biggest bore marked with a #
Temperature Range	-30 °C ~ 120 °C