

Safety Coupling  
with inner cone and outer cone

# KBK/BIA



optional  
nickel-plated version  
optional full stainless  
steel version

optional  
laserwelded

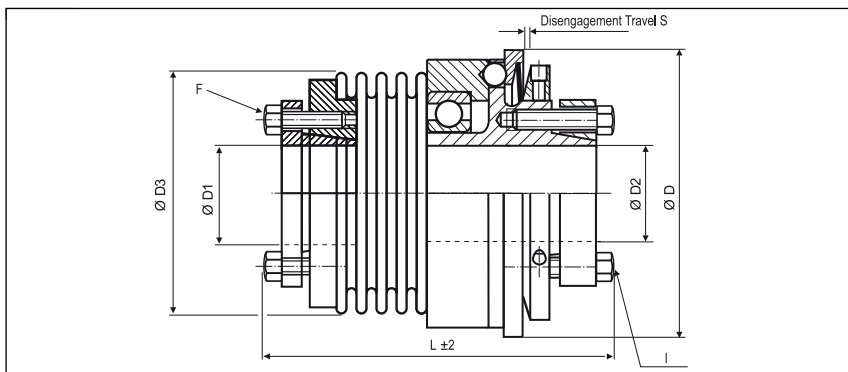

**Order Code**

**KBK/BIA - 60 - 100 - 15H7 - 18H7 - 20Nm - C or D - 2**

Type      Size      Length      ØD1 (H7)      ØD2 (H7)      Disengagement Torque      Torque Range  
C = Single Position    D = Multi Position Engagement

Size	Dimensions (mm)								Technical Data										
	Ø D	L	Ø D1	Ø D2	Ø D3	F	S	I	max. speed (1/min)	Mass (kg)	Moment of Inertia J (kg cm²)	Torque Range		Spring Stiffness			Misalignment		
	Outer Ø	Length	Bore Size (H7) min-max	Bore Size (H7) min-max	Screw ISO4017 TA (Nm)	Screw ISO4017 TA (Nm)	1 TKN (Nm)	2 TKN (Nm)				torsional x10³ CT (Nm/rad)	radial CR (N/mm)	axial CA (N/mm)	radial Δ Kr (mm)	axial Δ Ka (mm)	angular Δ Kw (°)		
-10	49	69	6-14	5-14	40.5	M3	0.7	M3	11650	0.27	0.6	3-7	5-10	8.1	120	27	0.15	0.4	1.5
		79	10#	10#		2.1		2.1						6.8	29	17	0.3	0.6	2
-30	64	74	12-20	12-20	56	M5	1.2	M5	9540	0.75	3.1	5-15	10-30	38	720	50	0.15	0.6	1.5
		83	14#	14#		6		5.9						28	225	28	0.25	1	2
-60	79	89	15-25	15-25	66	M6	1.2	M5	8180	1.43	8.8	12-35	20-60	75	1150	90	0.15	0.6	1.5
		100	18#	18#		8.5		8.7						50	340	50	0.25	1	2
-80	94	108	20-35	20-35	82	M6	2	M6	6220	2.5	22	15-40	30-80	128	1200	80	0.2	0.5	1.5
		120	27#	27#		14		15						75	400	50	0.25	0.8	2
-150	94	108	20-35	20-35	82	M6	2	M6	6220	2.5	22	50-130	65-150	155	2020	145	0.2	0.5	1.5
		120	27#	27#		14		15						105	595	85	0.25	0.8	2
-200	109	110	20-40	20-42	90	M6	2	M6	5720	2.9	34	30-90	80-200	175	2500	147	0.2	0.5	1.5
		123	32#	34#		14		15						116	460	82	0.25	0.8	2
-300	119	132	25-50	25-50	110	M8	2	M8	5200	4.9	73	60-200	150-300	502	6300	280	0.2	0.5	1.5
		143	41#	41#		18		25						285	1400	145	0.25	0.8	2
-500	129	149	35-55	35-55	122	M8	2	M8	4470	6.8	120	80-250	200-500	690	7790	100	0.2	0.5	1.5
		160	45#	45#		26		36						320	970	85	0.25	1	2
-800	169	243	50-70	50-70	157	M16	2	M12	3350	18	516	240-600	500-800	700	500	185	0.2	0.8	1.8
			58#	58#		45		85											
-1400	169	243	50-70	50-70	157	M16	2	M12	3350	18	520	360-1000	900-1400	1270	700	275	0.2	0.8	1.8
			58#	58#		80		115											

<b>Material</b>	outer cone - steel bellows – stainless steel inner cone - steel
<b>Keyway</b>	optional acc. DIN 6885 biggest bore marked with a #
<b>Temperature Range</b>	-30 °C ~ 120 °C