

Safety Coupling  
with inner cone and collet clamp

optional  
nickel-plated version  
optional full stainless  
steel version

optional  
laserwelded

# KBK/BIK

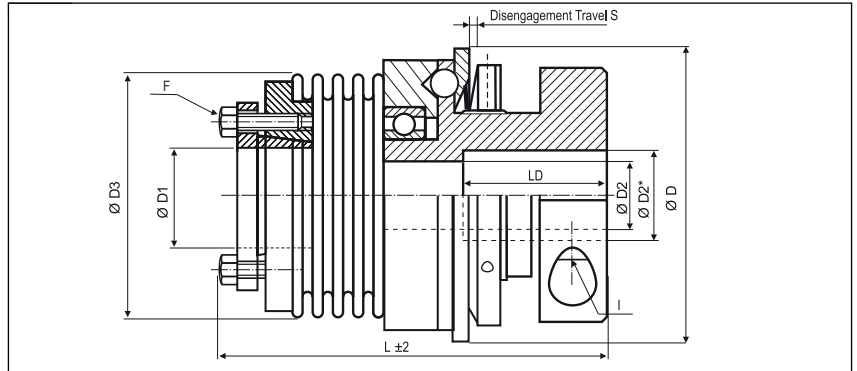

**Order Code**

**KBK/BIK - 60 - 107 - 15H7 - 18H7 - 20Nm - C or D - 2**

Type      Size      Length      ØD1 (H7)      ØD2 (H7)      Disengagement Torque      Torque Range  
C = Single Position    D = Multi Position Engagement

Size	Dimensions (mm)								Technical Data										
	Ø D	L	Ø D1	Ø D2	Ø D3	F	I	S	max. speed (1/min)	Mass (kg)	Moment of Inertia J (kg cm <sup>2</sup> )	Torque Range		Spring Stiffness			Misalignment		
	Outer Ø	Length	Bore Size (H7) min-max	Bore Size (H7) min-max		Screw ISO4017 TA (Nm)	Screw ISO4762 TA (Nm)	1 TKN (Nm)				2 TKN (Nm)	torsional x10 <sup>3</sup> CT (Nm/rad)	radial CR (N/mm)	axial CA (N/mm)	radial Δ Kr (mm)	axial Δ Ka (mm)	angular Δ Kw (°)	
-10	49	68	6-14	6-16	40.5	M3	M4	0.7	11650	0.27	0.6	3-7	5-10	8.1	120	27	0.15	0.4	1.5
		78	10#	11#		2.1	5.1							6.8	29	17	0.3	0.6	2
-30	64	79	12-20	10-20	56	M5	M6	1.2	9540	0.81	3.3	5-15	10-30	38	720	50	0.15	0.6	1.5
		88	14#	14#		6	15							28	225	28	0.25	1	2
-60	79	97	15-25	12-28	66	M6	M8	1.2	8180	1.48	9	12-35	20-60	75	1150	90	0.15	0.6	1.5
		107	18#	21#		8.5	36							50	340	50	0.25	1	2
-80	94	107	20-35	14-35	82	M6	M10	2	6220	3.2	28	15-40	30-80	128	1200	80	0.2	0.5	1.5
		119	27#	27#		14	72							75	400	50	0.25	0.8	2
-150	94	107	20-35	14-35	82	M6	M10	2	6220	3.2	28	50-130	65-150	155	2020	145	0.2	0.5	1.5
		119	27#	27#		14	72							105	595	85	0.25	0.8	2
-200	109	114	20-40	22-41	90	M6	M12	2	5720	3.9	46	30-90	80-200	175	2500	147	0.2	0.5	1.5
		127	32#	33#		14	125							116	460	82	0.25	0.8	2
-300	119	133	25-50	30-50	110	M8	M12	2	5200	6.1	92	60-200	150-300	502	6300	280	0.2	0.5	1.5
		143	41#	41#		18	125							285	1400	145	0.25	0.8	2
-500	129	147	35-55	35-56	122	M8	M12	2	4470	8.4	150	80-250	200-500	690	7790	100	0.2	0.5	1.5
		158	45#	46#		26	125							320	970	85	0.25	1	2

<b>Bores</b>	> Ø D2 and ≤ D2* only over LD
<b>Material</b>	bellows – stainless steel inner cone - steel collet clamp - aluminium; from Size 80 - steel
<b>Keyway</b>	optional acc. DIN 6885 biggest bore marked with a #
<b>Temperature Range</b>	-30 °C ~ 120 °C

<b>Size</b>	2	45	7	10	30	60	80	150	200	300	500
<b>D2*</b>	11	X	20	20	26	31	38	38	X	57	62
<b>LD</b>	15	X	20	20	28	38	34	34	X	42	56