

Safety Coupling
with two outer cones

optional
nickel-plated version
optional full stainless
steel version

KBK/EAA

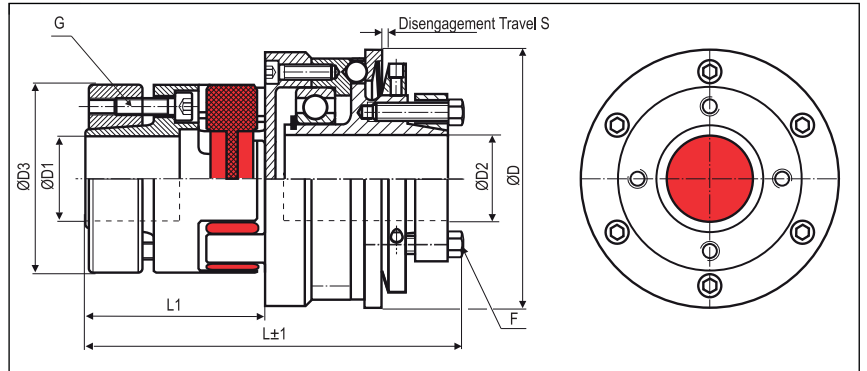

Order Code

KBK/EAA - 24 - 119.5 - 16H7 - 15H7 - 20Nm - C or D - 2

Type	Size	Length	ØD1 (H7)	ØD2 (H7)	Disengagement Torque	Torque Range
						C = Single Position D = Multi Position Engagement

Size	Dimensions (mm)									Technical Data								
	Ø D	L	Ø D1	Ø D2	Ø D3	G	F	L1	S	max. speed (1/min)	Mass (kg)	Moment of Inertia J (kg cm ²)	Torque 98 Sh TKN (Nm)	Torque Range		Misalignment		
	Outer Ø	Length	Bore Size (H7) min-max	Bore Size (H7) min-max		Screw ISO4762 TA (Nm)	Screw ISO4017 TA (Nm)							1 TKN (Nm)	2 TKN (Nm)	radial Δ Kr (mm)	axial Δ Ka (mm)	angular Δ Kw (°)
-14	49	75	6-14	5-14	30	M3	M3	32	0.7	11690	0.29	0.7	12.5	3-7	5-10	0.09	+1.0	0.9
		70	10#	10#		1.34	2.1	27									-0.5	
-19	64	96	10-19	12-20	40	M4	M5	41	1.2	8950	0.79	3.2	17	5-15	10-30	0.06	+1.2	0.9
		91	13#	14#		2.9	6	36									-0.5	
-24	79	119.5	15-28	15-25	55	M5	M5	50	1.2	7630	1.62	9.9	60	12-35	20-60	0.10	+1.4	0.9
		112.5	21#	18#		6	8.7	43									-0.5	
-28	94	143.5	19-38	20-35	65	M5	M6	59	2	6030	2.8	24	160	50-130	65-150	0.11	+1.5	0.9
		136.5	30#	27#		6	15	52									-0.7	
-38	119	160	20-45	25-50	80	M6	M8	67	2	4980	5.3	79	325	60-200	150-300	0.12	+1.8	0.9
		151	37#	42#		10	25	58									-0.7	
-42	129	189	28-50	35-55	95	M8	M8	76	2	4440	9.8	174	450	80-250	200-500	0.14	+2.0	0.9
		177.5	42#	45#		35	36	64									-1.0	

Material	outer cone: steel outer cone: steel spider element: polyurethane 98 Sh A (red)
Keyway	optional acc. DIN 6885 biggest bore marked with a #
Temperature Range	-30 °C ~ 90 °C