

Safety Coupling
with collet clamp and inner cone

optional
nickel-plated version
optional full stainless
steel version

KBK/EKI

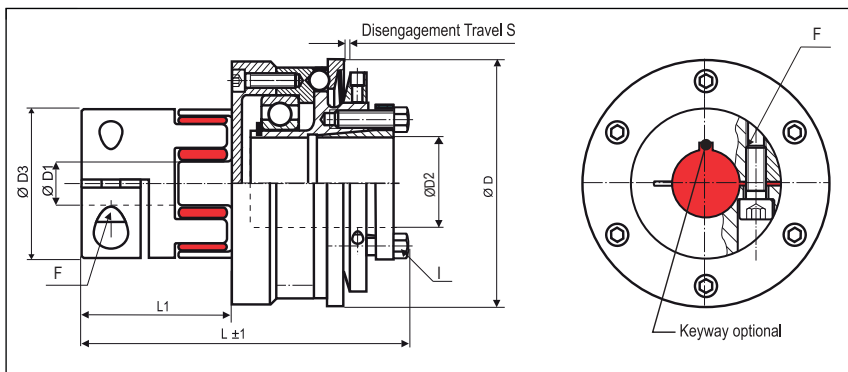

Order Code

KBK/EKI - 24 - 111.5 - 16H7 - 15H7 - 20Nm - C or D - 2

Type	Size	Length	ØD1 (H7)	ØD2 (H7)	Disengagement Torque	Torque Range
						C = Single Position D = Multi Position Engagement

Size	Dimensions (mm)									Technical Data								
	Ø D	L	Ø D1	Ø D2	Ø D3	F	I	L1	S	max. speed (1/min)	Mass (kg)	Moment of Inertia J (kg cm ²)	Torque 98 Sh TKN (Nm)	Torque Range		Misalignment		
	Outer Ø	Length	Bore Size (H7) min~max	Bore Size (H7) min~max		Screw ISO4762 TA (Nm)	Screw ISO4017 TA (Nm)							1 TKN (Nm)	2 TKN (Nm)	radial Δ Kr (mm)	axial Δ Ka (mm)	angular Δ Kw (°)
-14	49	65	4-16	6-14 10#	30	M3 1.4	M3 2.1	24	0.7	11690	0.24	0.6	12.5	3-7	5-10	0.09	+1.0 -0.5	0.9
-19	64	93 85	10-22	12-20 14#	40	M6/11 M6/11	M5 6	41 33	1.2	8950	0.74	3.0	17	5-15	10-30	0.06	+1.2 -0.5	0.9
-24	79	111.5 101.5	15-32	15-25 18#	55	M6/11 M6/11	M6 8.5	50 40	1.2	7630	1.42	8.7	60	12-35	20-60	0.10	+1.4 -0.5	0.9
-28	94	135 121	19-38	20-35 27#	65	M8/25 M8/25	M6 14	59 45	2	6030	2.4	21	160	50-130	65-150	0.11	+1.5 -0.7	0.9
-38	119	151 137	20-45	25-50 41#	80	M8/25 M10/49	M8 20	67 53	2	4980	4.6	69	325	60-200	150-300	0.12	+1.8 -0.7	0.9
-42	129	175	28-45	35-55 45#	95	M10 70	M8 26	76	2	4440	6.7	120	450	80-250	200-500	0.14	+2.0 -1.0	0.9

Material	inner cone: steel collet clamp: aluminium spider element: polyurethane 98 Sh A (red)
Hub Style	size 14 and 19: single slit** size 24, 28, 38, 42: double slit ** short lengths are automatically with single slits
Keyway	optional acc. DIN 6885 biggest bore marked with a #
Temperature Range	-30 °C ~ 90 °C