

Safety Coupling
with keyway and inner cone

optional
nickel-plated version
optional full stainless
steel version

KBK/EPI

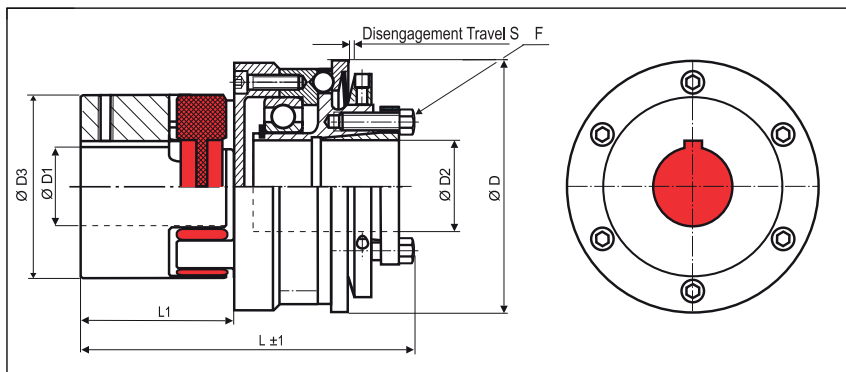

Order Code

KBK/EPI - 24 - 111.5 - N16H7 - 15H7 - 20Nm - C or D - 2

Type Size Length ØD1 (H7) ØD2 (H7) Disengagement Torque Torque Range

C = Single Position D = Multi Position Engagement

Size	Dimensions (mm)								Technical Data								
	Ø D	L	Ø D1	Ø D2	Ø D3	F	L1	S	max. speed (1/min)	Mass (kg)	Moment of Inertia J (kg cm ²)	Torque 98 Sh TKN (Nm)	Torque Range		Misalignment		
	Outer Ø	Length	Bore Size (H7) min-max	Bore Size (H7) min-max		Screw ISO4017 TA (Nm)							1 TKN (Nm)	2 TKN (Nm)	radial Δ Kr (mm)	axial Δ Ka (mm)	angular Δ Kw (°)
-14	49	65	6-16	6-14 10#	30	M3 2.1	24	0.7	11690	0.22	0.5	12.5	3-7	5-10	0.09	+1.0 -0.5	0.9
-19	64	93	10-24	12-20 14#	40	M5 6	41	1.2	8950	0.72	2.9	17	5-15	10-30	0.06	+1.2 -0.5	0.9
-24	79	111.5	16-28	15-25 18#	55	M6 8.5	50	1.2	7630	1.3	7.9	60	12-35	20-60	0.10	+1.4 -0.5	0.9
-28	94	135	20-38	20-35 27#	65	M6 14	59	2	6030	2.28	20	160	50-130	65-150	0.11	+1.5 -0.7	0.9
-38	119	151	20-45	25-50 41#	80	M8 20	67	2	4980	4.6	69	325	60-200	150-300	0.12	+1.8 -0.7	0.9
-42	129	175	20-55	35-55 45#	95	M8 26	76	2	4440	8.75	156	450	80-250	200-500	0.14	+2.0 -1.0	0.9

Material
inner cone: steel
hubs: aluminium
spider element: polyurethane 98 Sh A (red)

Keyway
optional acc. DIN 6885
biggest bore marked with a #

Temperature Range
-30 °C ~ 90 °C