

Safety Coupling
with two keyways

optional
nickel-plated version
optional full stainless
steel version

KBK/EPP

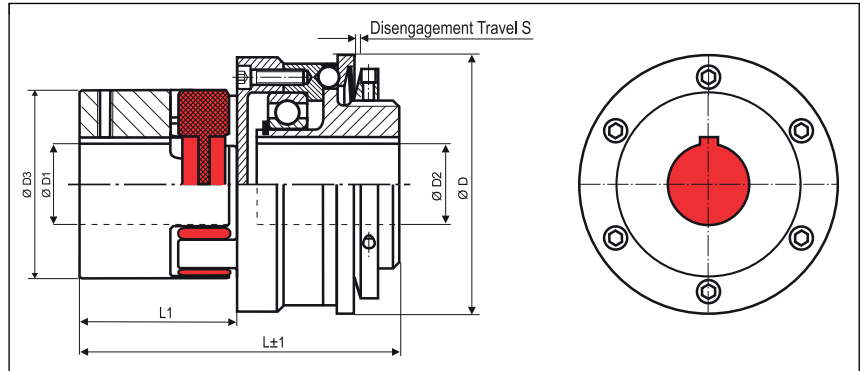

Order Code

KBK/EPP - 24 - 98.5 - N16H7 - N15H7 - 20Nm - C or D - 2

Type	Size	Length	ØD1 (H7)	ØD2 (H7)	Disengagement Torque	Torque Range
					C = Single Position D = Multi Position Engagement	

Size	Dimensions (mm)							Technical Data								
	Ø D	L	Ø D1	Ø D2	Ø D3	L1	S	max. speed (1/min)	Mass (kg)	Moment of Inertia J (kg cm ²)	Torque 98 Sh TKN (Nm)	Torque Range		Misalignment		
	Outer Ø	Length	Bore Size (H7) min-max	Bore Size (H7) min-max			1 TKN (Nm)					2 TKN (Nm)	radial Δ Kr (mm)	axial Δ Ka (mm)	angular Δ Kw (°)	
-14	49	55	6-16	6-12	30	24	0.7	11690	0.19	0.5	12.5	3-7	5-10	0.09	+1.0 -0.5	0.9
-19	64	81	10-24	10-16	40	41	1.2	8950	0.63	2.6	17	5-15	10-30	0.06	+1.2 -0.5	0.9
-24	79	98.5	16-28	15-24	55	50	1.2	7630	1.1	6.8	60	12-35	20-60	0.10	+1.4 -0.5	0.9
-28	94	121	20-38	19-29	65	59	2	6030	2	17	160	50-130	65-150	0.11	+1.5 -0.7	0.9
-38	119	134	20-45	20-42	80	67	2	4980	3.8	57	325	60-200	150-300	0.12	+1.8 -0.7	0.9
-42	129	157	20-55	20-50	95	76	2	4440	7.9	140	450	80-250	200-500	0.14	+2.0 -1.0	0.9

Material	hubs: aluminium spider element: polyurethane 98 Sh A (red)
Temperature Range	-30 °C ~ 90 °C