

Safety Coupling
with outer cone and two bearings

optional
nickel-plated version
optional full stainless
steel version

KBK/LLA

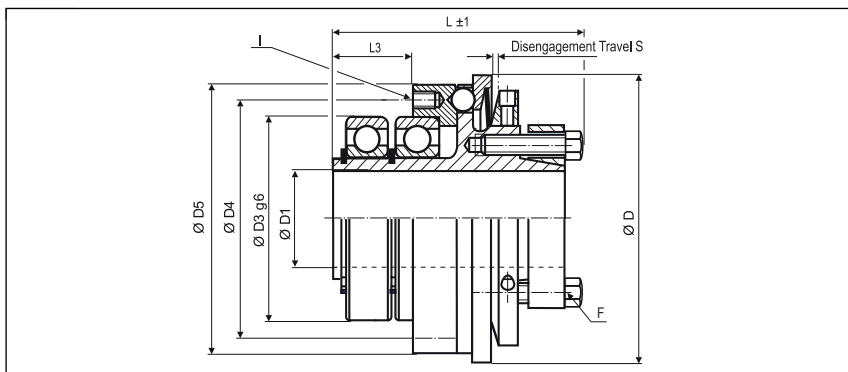

Order Code

KBK/LL-A - 60 - 20H7 - 20Nm - C or D - 2

Type

Size

ØD1
(H7)

Disengagement
Torque

Torque
Range

C = Single Position D = Multi Position Engagement

Size	Dimensions (mm)										Technical Data				
	Ø D	Ø D1	Ø D3	Ø D4	Ø D5	L	L3	S	I	F	Torque Range		max. speed (1/min)	Mass (kg)	Moment of Inertia J (kg cm ²)
	Outer Ø	Bore Size (H7) min~max				Length		6x	Screw ISO4017 T _A (Nm)	1 T _{KN} (Nm)	2 T _{KN} (Nm)				
-10	49	5-12 10#	37	42	47	47.5	15	0.7	M3	M3 2.1	3-7	5-10	12000	0.21	0.5
-30	64	12-20 14#	47	53	60	61.5	20	1.2	M4	M5 5.9	5-15	10-30	9400	0.62	2.6
-60	79	15-25 18#	62	69	75	83	26	1.2	M5	M5 8.7	13-35	20-65	7800	1.16	7.1
-80	94	20-35 27#	68	80	90	84.5	27	2	M6	M6 15	15-40	30-80	6400	1.97	17
-150	94	20-35 27#	68	80	90	84.5	27	2	M6	M6 15	50-130	65-150	6400	1.97	17
-200	109	20-42 34#	80	90	105	93.5	28	2	M6	M6 15	30-90	80-200	5500	2.30	27
-300	119	25-50 42#	90	102	115	103.5	31	2	M8	M8 25	60-200	150-300	5000	3.7	56
-500	129	35-55 45#	100	112	125	109	31	2	M8	M8 36	80-250	200-500	4500	5.3	95
-800	169	50-70 58#	110	125	165	141	38	2	M12	M12 85	260-600	500-900	3500	15	438
-1400	169	50-70 58#	110	125	165	141	38	2	M12	M12 115	450-900	800-1400	3500	15	438

Keyway

optional acc. DIN 6885

biggest bore marked with a #

Temperature Range

-30 °C ~ 120 °C