

Metal Bellows Coupling  
with stainless steel collet clamps

optional  
laserwelded

# KB4VA

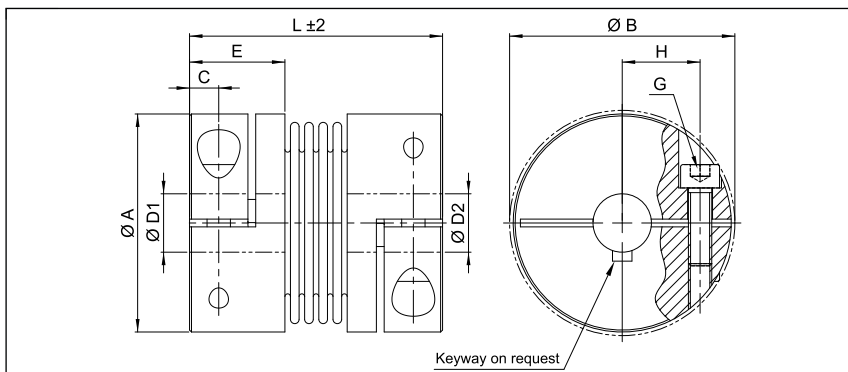
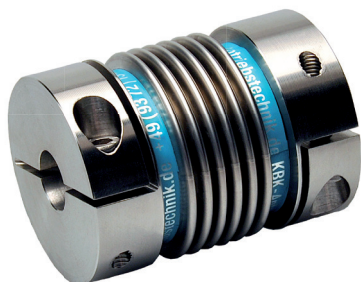

Order Code

**KB4 / 60 - 89 - 12 - 32 - VA/VAW**

Type / Size

Length  
L

ØD1  
(H7)

ØD2  
(H7)

Stainless Steel  
glued / laserwelded

Size	Torque TKN (Nm)	Dimensions (mm)								Technical Data								
		L	Ø A	Ø D1/D2	H	C	E	Ø B	F	Mass (kg)	Moment of Inertia J (g m²)	Spring Stiffness			Misalignment			max speed min-1
		Length	Outer Ø	Bore Sizes (H7) min-max					Screw (ISO4762) TA (Nm)			torsional CT 10³ (Nm/rad)	radial CR (N/mm)	axial CA (N/mm)	radial ΔKr (mm)	axial ΔKa (mm)	angular ΔKw (°)	
18	18	63	45	10-25.4	17	5.5	19.5	47.4	M5	0.27	0.11	20	205	50	0.2	0.5	1.5	12800
		8							0.41	0.14	15	82	36	0.25	0.5	2	12800	
30	30	65	56	10-32	20	7.5	24.5	56.4	M6	0.83	0.41	38	720	50	0.15	0.6	1.5	10300
		15							0.89	0.44	28	225	28	0.25	1	2	10300	
60	60	79	66	12-35	23	10	29	66	M8	1.4	0.91	75	1150	90	0.15	0.6	1.5	8700
		40							1.7	1.00	50	340	50	0.25	1	2	8700	
80	80	91	82	14-44	28	11	33.5	82.9	M10	2.3	2	128	1200	80	0.2	0.5	1.5	6900
		84							2.4	2.1	75	400	50	0.25	0.8	2	6900	
150	150	91	82	19-44	28	11	33.5	82.9	M10	2.3	2	155	2020	145	0.2	0.5	1.5	6900
		84							2.4	2.1	105	595	85	0.25	0.8	2	6900	
200	200	101	90	22-47	31	13	38	90.8	M12	2.6	3.3	175	2500	145	0.2	0.5	1.5	6400
		125							2.7	3.5	120	460	82	0.25	0.8	2	6400	
300	300	105	110	30-60	40	13	38	110	M12	3.6	7.3	502	6300	280	0.2	0.5	1.5	6000
		145							3.7	7.5	285	1400	145	0.25	0.8	2	6000	
500	500	112	122	35-70	42	15	42	122	M12	5.1	12.4	690	7790	100	0.2	0.5	1.5	5000
		145							5.2	12.7	320	970	85	0.25	1	2	5000	

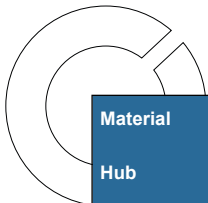

<b>Material</b>	bellows - stainless steel hub - stainless steel
<b>Hub</b>	bore tolerance: H7
<b>Temperature Range</b>	VA -30 °C ~ 120 °C (glued) VAW -30 °C ~ 250 °C (laserwelded)
<b>Keyway</b>	optional acc. DIN 6885 biggest bore marked with a #