

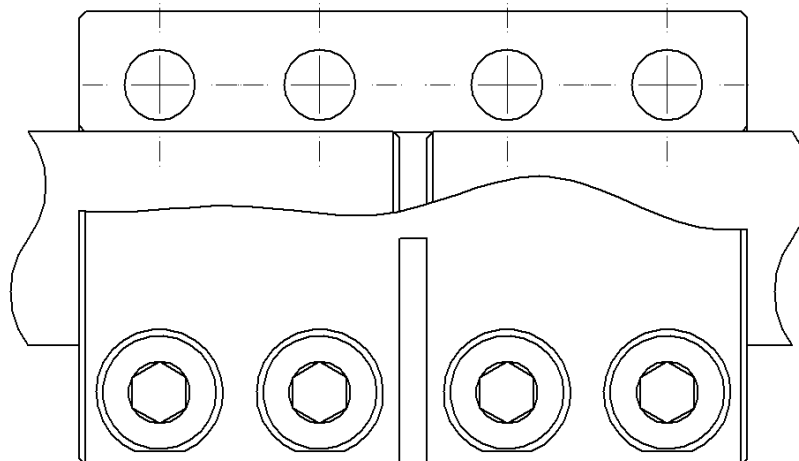

Slit Rigid Shaft Coupling KBST2-G / KBST2-G-VA

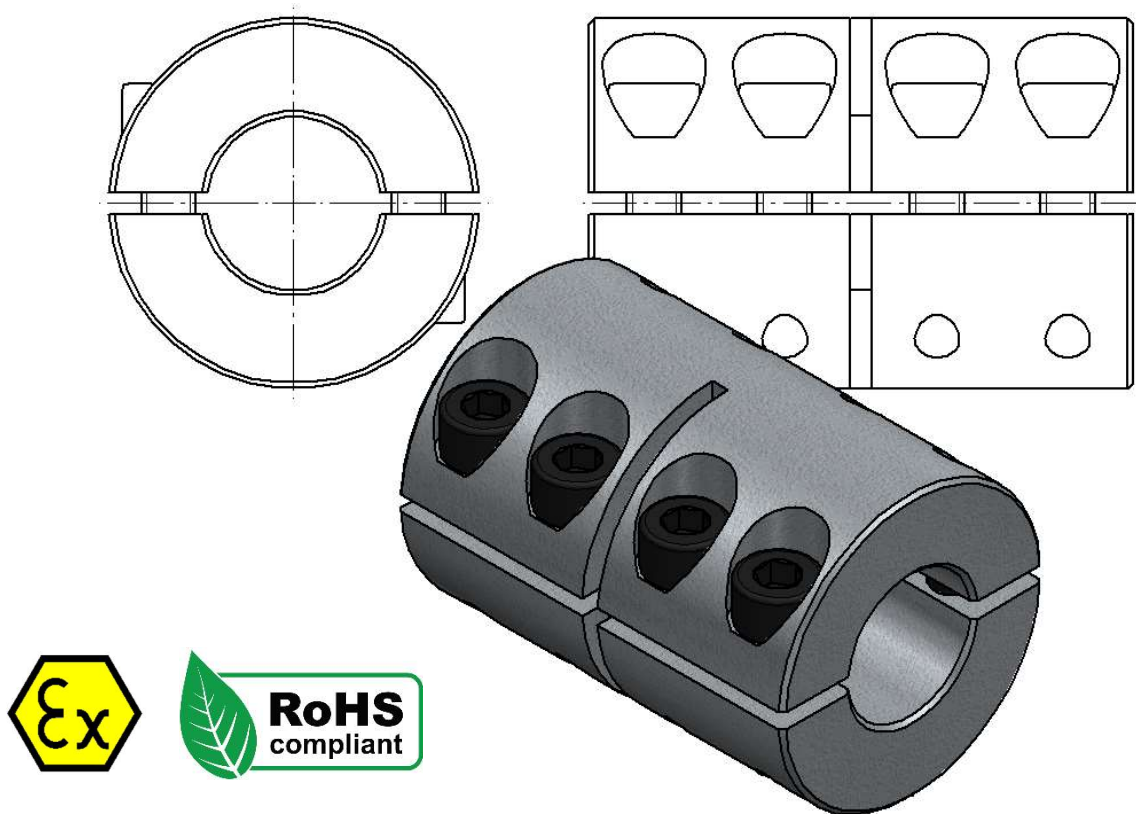

The **slit rigid shaft coupling KBST2-G / KBST2-G-VA** is a frictionally engaged, detachable shaft-shaft connection for cylindrical shafts with and without keyway.

 The couplings are available in ATEX version. Please note the supplementary operating- and assembly instructions for areas with potentially explosive atmospheres.

Characteristics

- generally delivered fully assembled
- true-running accuracy **0,02 – 0,04 mm**

Tolerances, Surfaces

- One accurate rotating process is sufficient: **Rz ≤ 16 µm**
- KBK slit rigid shaft couplings do have an H7 fit. The recommended fitting tolerance is **0,02mm - 0,05mm**.

Components of the slit rigid shaft coupling KBST2-G / KBST2-G-VA

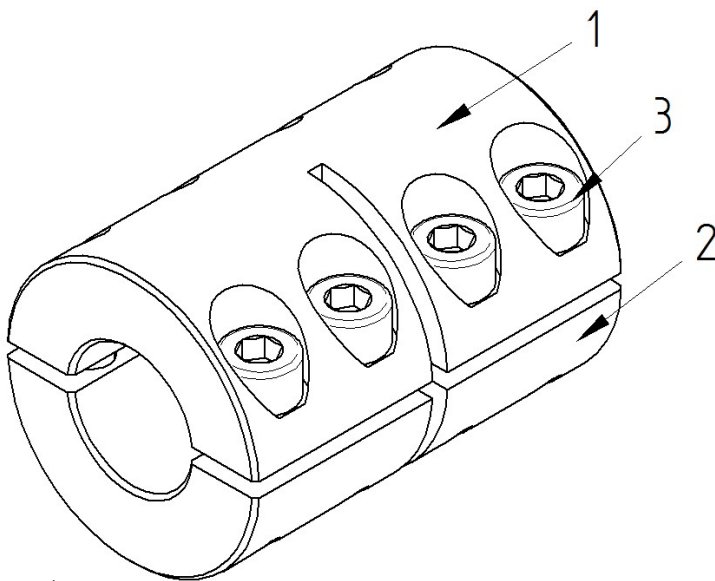



Image 2) KBST-G

Component	Quantity	Description
1	1	Upper coupling half
2	1	Lower coupling half
3	8	Head screw with hexagon socket ISO 4762

 Information!	Contaminated or used shaft couplings have to be disassembled and cleaned prior to installation. Then apply a thin layer of a low-viscosity oil (e.g. Castrol 4 in 1 or Klüber Quietsch Ex).
--	---

Assembly of the coupling

- Check the shaft-position regarding the permitted tolerance (fitting tolerance: 0,02mm - 0,05mm).
- Clean and degrease the contact surfaces of the shafts to be connected. Then apply a thin layer of low-viscosity oil (e.g. Castrol 4 in 1 or Klüber Quietsch Ex).



Attention!

Do not use any oil or grease including molybdenum disulphide or extreme pressure additives as well as sliding grease-pastes.

- Unscrew and remove the clamping screws and put the coupling halves of the rigid shaft coupling KBST2-G onto the shaft ends to be connected.
- Slightly tighten the clamping screws manually and align both the rigid shaft coupling and the shafts (see image 3).

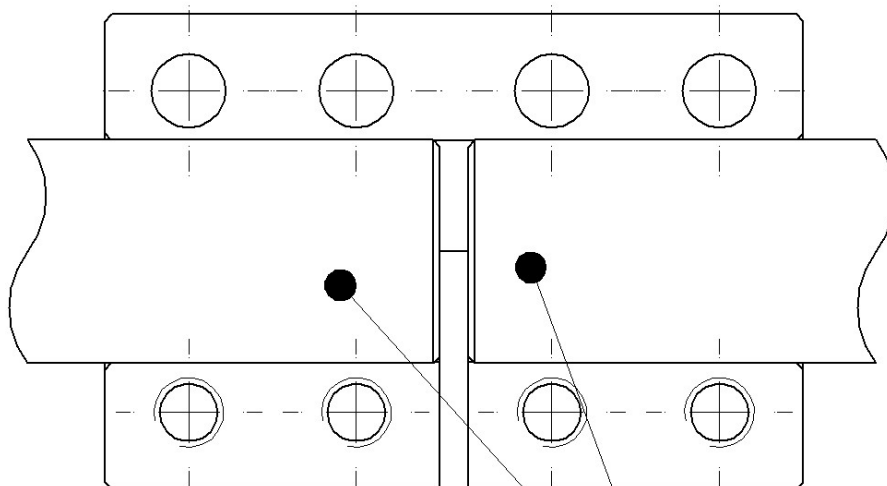

Image 3) Aligning the rigid shaft coupling

shaft ends must
be aligned

- Tighten the clamping screws evenly and in sequence. Increase the tightening torque gradually. Repeat this procedure, until the tightening torque specified in table 1 is reached for all clamping screws.

Table 1:

Rigid shaft coupling	KBST2-G						
Size	5	6	8	10	12	14	15
Screw size	M3	M3	M3	M4	M4	M5	M5
Torque _{T_A} [Nm]	2	2	5	5	5	10	10

Size	16	20	25	30	35	40	50
Screw size	M5	M6	M6	M6	M8	M8	M10
Torque T _A [Nm]	10	17	17	17	42	42	83

Rigid shaft coupling	KBST2-G-VA						
Size	6	8	10	12	14	15	16
Screw size	M3	M3	M4	M4	M5	M5	M5
Torque _{T_A} [Nm]	1,6	1,6	3,9	3,9	7,6	7,6	7,6

Size	20	25	30	35	40	50
Screw size	M6	M6	M6	M8	M8	M10
Torque T _A [Nm]	13,2	13,2	13,2	32	32	63

Disassembly of the coupling



Danger!

Loosened or falling drive components can cause personal injury or machine damages. Secure the drive components prior to disassembly.

- Loosen all clamping screws evenly in sequence. Completely unscrew the clamping screws and remove the half shells.



Attention!

Non-compliance with these instructions as well as disregarded operating conditions dimensioning the shaft coupling can influence the function of the coupling.

Disposal: *Defective shaft couplings must be cleaned and disposed.*